 **Pearl**[®]
Water Systems

Convertible Jet Pump



CONVERT

Pearl[®] **CONVERT** Convertible Jet Pump

CONVERT is part of the PEARL Jet Pumps family.

The versatility of this pump allows it to be used in many different applications, such as shallow or deep wells. Regardless of its configuration, CONVERT is a self-priming pump, which means that, after the first priming, there is no need for the pump to be primed again.

The pump's design and features guarantee complete customer satisfaction. Every component was carefully manufactured with the best materials to ensure the best performance and reliability possible.

CONVERT'S construction is suitable for outdoor applications.

CONVERT comes equipped with a PEARL pressure switch for quick installation.

One of the biggest advantages of using CONVERT is the ability to service the pump without removing the pipes from the adapter.



Applications

- Domestic water supply out of a well at desirable pressure.
- Lifting water containing air or other gasses.
- Boost pressure from flooded suction.
- Garden maintenance (see operating conditions).

Operating Conditions

- Liquid temperature: 32° F - 150° F.
- Maximum working pressure: 125 PSI.
- Continuous duty.

Construction

- Closed coupled self-priming centrifugal pump.
- High-quality components for domestic use and irrigation meeting low lead requirements.
- Connection threaded ports NPT.
- Stainless Steel hardware.
- Pre-drilled priming port with plug.
- Pre-drilled drain port with plug for maintenance.
- U-shaped base for pump support.
- U-shape base for pump support..

Motor

- NEMA Standard ODP 56J motor for cooler surface temperatures .
- Thermal overload protection .
- Capacitor start/capacitor run type motor for ½ - ¾ hp versions.
- Permanent Split Capacitor (PSC) without centrifugal switch for 1 hp and 1½ hp versions .
- Front bearing 6204 for longer life spans .
- All copper windings cCSAus Approved Class F Dupont Nomex Insulation System .
- Single phase 115/230V for ½, ¾, 1, and 1 ½ hp models .
- Easy voltage conversion .
- Maximum Ambient Temperature: 40 °C (104 °F).
- Assembled with PEARL Pressure Switch.

ACCESSORIES

The following accessories are required for proper jet pump operation:

- Shallow Well Kit: Includes shallow well adapter and venturi and nozzle kits
- Twin Pipe Deep Well Kit: Include the 4" jet body, venturi and nozzle kits, and the foot valve
- Single Pipe Packer: Includes packer body, venturi and nozzle kits, and the foot valve

*Note: The Single Packer also requires a well adapter

Convertible Jet Pump

PERFORMANCE & TECHNICAL DATA

SHALLOW WELL PERFORMANCE

MODEL	HP	SHALLOW WELL PACKAGE	ADAPTER	NOZZLE	VENTURI	TOTAL SUCTION LIFT [FEET]	DISCHARGE PRESSURE - PSI					MAX. SHUT OFF [PSI]
							20	30	40	50	60	
							FLOW US GPM					
CONVERT 05	0.5	SWJP-05	SW-ADP	PNZL-C	PVNT-C31	5	16.7	16.4	12.2	6.4	-	63
						10	15.2	15	10	4.8	-	60
						15	12.7	12.8	9.1	4	-	58
						20	10.5	10.4	9.1	3.6	-	58
CONVERT 05	0.5	SWJP-05H	SW-ADP	PNZL-E	PVNT-B28	25	8.2	8.1	8	2.7	-	56
						5	12	11.7	11.5	8.3	5	80
						10	10.6	10.5	10.3	7.3	4	79
						15	9	8.9	8.3	6	3.5	77
CONVERT 07	0.75	SWJP-07	SW-ADP	PNZL-D	PVNT-B36	20	7.1	7.1	7	6.4	3.5	75
						25	5.7	5.7	5.7	5.7	3	74
						5	-	22.6	21.5	14.6	8.5	72
						10	-	20.9	19.4	12.6	6.6	69
CONVERT 10	1.0	SWJP-10	SW-ADP	PNZL-D	PVNT-B38	15	-	17.6	17.4	11.7	5.1	68
						20	-	14.4	14.4	12.5	5.4	67
						25	-	11.5	11.5	10.3	3.1	64
						5	-	24.2	24	18.9	11	73
CONVERT 15	1.5	SWJP-15	SW-ADP	PNZL-H	PVNT-B42	10	-	21.5	21.4	15.6	7.3	70
						15	-	19.2	19.1	16.9	8.4	69
						20	-	15.7	15.5	14.2	7	68
						25	-	12.6	12.5	11.7	4.1	65
CONVERT 15	1.5	SWJP-15	SW-ADP	PNZL-H	PVNT-B42	5	-	24.6	24.5	24.4	20	90
						10	-	22.6	22.5	22.5	17.6	84
						15	-	19.1	19	19	17.6	83
						20	-	16.5	16.4	16.4	15.14	82
CONVERT 15	1.5	SWJP-15	SW-ADP	PNZL-H	PVNT-B42	25	-	13.1	13.1	13.1	12.8	77

DEEP WELL 2" SINGLE PIPE PERFORMANCE

MODEL	HP	SUCTION PIPE SIZE (IN.)	JET ASSEMBLY PACKAGE	JET BODY (ONLY)	NOZZLE	VENTURI	CONTROL VALVE SETTING (PSI)	30-50 PSI PRESSURE SWITCH SETTING	DEPTH TO JET ASSEMBLY IN FEET (BASED ON SUBMERGENCE OF 5 FEET)							
									30	40	50	60	70	80	90	100
CONVERT 05	0.5	1 1/4	2DWJP-05-40	2DWJB	PNZL-C	PVNT-A26	30	30-50 PSI PRESSURE SWITCH SETTING	10.2	9	-	-	-	-	-	-
			2DWJP-05-60		PNZL-B	PVNT-A23	30		7.9	6.5	6.3	5.4	-	-	-	-
			2DWJP-05-80		PNZL-A	PVNT-A20	30		-	-	-	4.3	3.9	3.5	-	-
CONVERT 07	0.75	1 1/4	2DWJP-07-60	2DWJB	PNZL-A	PVNT-A27	30	30-50 PSI PRESSURE SWITCH SETTING	12.1	11.7	10.2	7.5	-	-	-	-
			2DWJP-07-90		PNZL-A	PVNT-A23	30		-	-	-	6.5	6	4.5	3.9	-
CONVERT 10	1.0	1 1/4	2DWJP-10-60	2DWJB	PNZL-B	PVNT-A29	35	30-50 PSI PRESSURE SWITCH SETTING	13.3	11.2	10.4	9.1	-	-	-	-
			2DWJP-10-100		PNZL-B	PVNT-A25	36		-	-	-	7.1	6.8	5.1	4.6	3.8

DEEP WELL 4" TWIN PIPE PERFORMANCE

MODEL	HP	DRIVE PIPE PIPE SIZE [IN]	SUCT PIPE SIZE [IN]	JET ASSEMBLY PACKAGE	JET BODY (ONLY)	NOZZLE	VENTURI	CONTROL VALVE SETTING (PSI)	GALLONS PER MINUTE (GPM) 30-50 PSI PRESSURE SWITCH SETTING	DEPTH TO JET ASSEMBLY IN FEET (BASED ON SUBMERGENCE OF 5 FEET)														
										30	40	50	60	70	80	90	100	110	120	130	140	150		
CONVERT 05	0.5	1	1 1/4	4DWJP-05-40	4DWJB	PNZL-C	PVNT-A26	30	30-50 PSI PRESSURE SWITCH SETTING	9	7.2	-	-	-	-	-	-	-	-	-	-	-		
				4DWJP-05-60		PNZL-B	PVNT-A23	30		8.8	6.8	4.8	4.1	-	-	-	-	-	-	-	-			
				4DWJP-05-90		PNZL-A	PVNT-A20	30		-	-	-	3.7	2.6	2.2	1.5	-	-	-	-	-	-		
CONVERT 07	0.75	1	1 1/4	4DWJP-07-60	4DWJB	PNZL-C	PVNT-A29	30	30-50 PSI PRESSURE SWITCH SETTING	14.5	14.3	12.1	7.8	-	-	-	-	-	-	-	-	-		
				4DWJP-07-90		PNZL-B	PVNT-A25	30		-	-	-	-	5.1	3.4	1.9	-	-	-	-	-			
				4DWJP-07-110		PNZL-B	PVNT-A22	30		-	-	-	-	-	1.7	1.3	0.8	-	-	-	-			
CONVERT 10	1.0	1	1 1/4	4DWJP-10-60	4DWJB	PNZL-C	PVNT-A30	31	30-50 PSI PRESSURE SWITCH SETTING	16.3	14.3	11.6	7.8	-	-	-	-	-	-	-	-	-		
				4DWJP-10-80		PNZL-C	PVNT-A27	35		-	-	-	9.6	7.2	4.5	-	-	-	-	-				
				4DWJP-10-110		PNZL-B	PVNT-A22	35		-	-	-	-	-	4.3	3.1	2.9	1.5	-	-	-			
CONVERT 15	1.5	1 1/4	1 1/2	4DWJP-15-70	5DWJB	PNZL-E	PVNT-A34	35	30-50 PSI PRESSURE SWITCH SETTING	19	15.1	11	8.1	3.8	-	-	-	-	-	-	-			
				4DWJP-10-150		PNZL-D	PVNT-A27	40		-	-	-	-	5.3	4.4	2.8	2.6	2	1.7	1.3	0.9	0.5		



Pearl[®]

CONVERT

Convertible Jet Pump

DEEP WELL APPLICATIONS

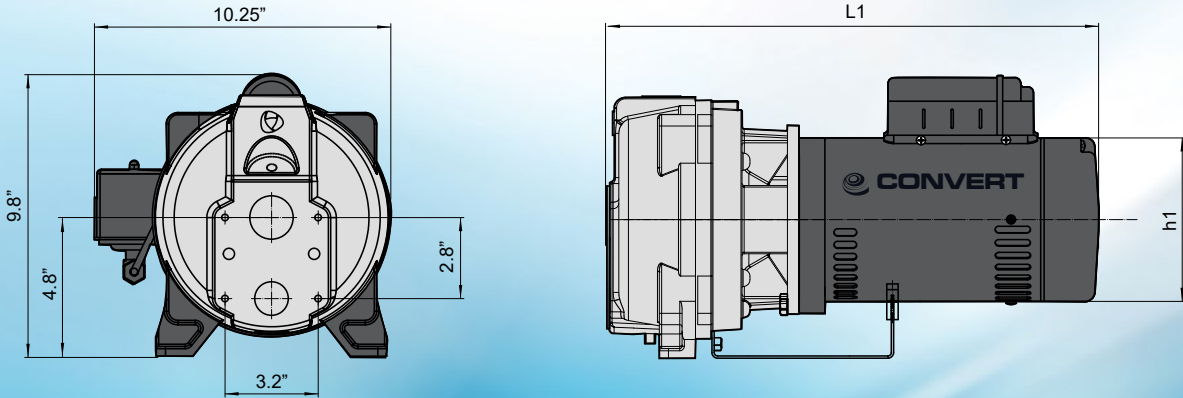

SHALLOW WELL APPLICATIONS

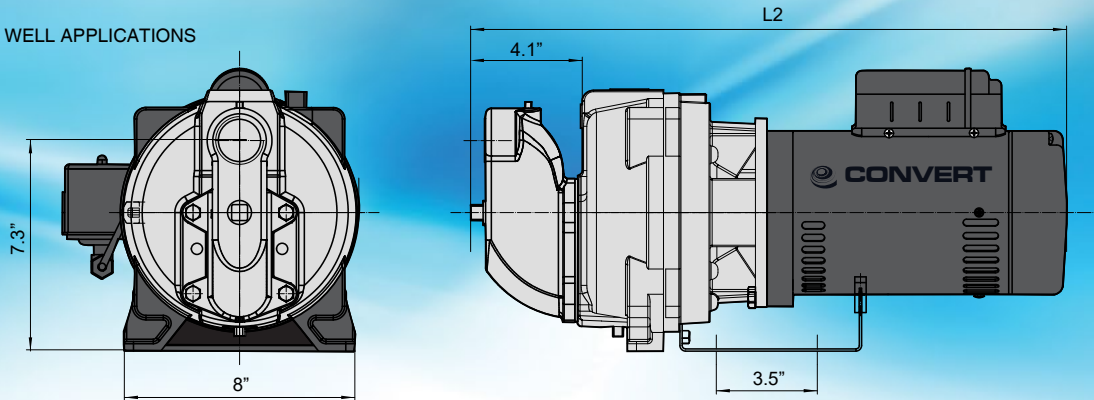

Pump Dimensions

MODEL	SUCTION	DISCHARGE	DIMENSIONS			WEIGHT [lbs]
	DN	DN	h1	L1	L2	
CONVERT 05-07	1.5"	1.25"	9.8"	16.6"	20.7"	54
CONVERT 10	1.5"	1.25"	9.8"	17.4"	21.5"	66
CONVERT 15	1.5"	1.25"	9.8"	18"	22.1"	70

Packaging Dimensions

MODEL	L	W	H	WEIGHT [lbs]
CONVERT 05-07	11.75"	22.25"	12.75"	60
CONVERT 10	11.75"	22.25"	12.75"	72
CONVERT 15	11.75"	22.25"	12.75"	76

